



EAA 485 JUNE 2024

HOME OF THE "PANHANDLE PELICANS"

PRESIDENT'S NOTES: Contact: [Ralph Moser](#)

Many thanks to Duane "Drano" Thiessen for running the May meeting. I understand guest speaker Virgil Zetterlind gave a great presentation at the meeting; sorry I missed it. I was enjoying myself immensely in Cincinnati with my wife Paula, at our 50-year USAF UPT graduation reunion!

Your next opportunity to volunteer at a chapter event will be June 15th, when we once again fly Young Eagles rides for the high school men and women attending the summer Chappie James Flight Academy. For those of you new to the chapter unfamiliar with this, please read all about the school online. We have supported this wonderful program with Young Eagles flights for 12+ years.

We have just been notified of another aircraft kit offered as a donation to the chapter. It is a Zenith 601XL, still in the crate. It includes the "B" mod kit, and a Jabaru 3300 engine. Located in Pace, FL. Several of our Zenith experts are looking it over to make sure there are no surprises. We are working on interim storage space, the logistics of moving a 900 pound, 12' long crate, etc. Expect us to auction this off as a fund raiser for the chapter, hopefully to an interested party from within the chapter, like we did the CH750 kit donation last year. We will provide a detailed update at the June meeting.

Lastly, Air Venture 2024 is coming up fast! Some of us will be flying up or driving up. If the idea of attending the world's largest air show intrigues you, talk to those of us who have "been there" about the logistics involved. Those flying their plane up may have an empty seat or two available. Member Mike Danford again offers his friend's hangar floor to camp out at KOSH, directly across the runway from the show! Contact member Cody Rhoades, who utilized this "no-cost" camping option last year, for details.

—Ralph

Ray Scholarship Update:

Kaydee Macdonald is moving right along. She recently completed her long solo cross country. She is now preparing for the written and hopes to take her check ride late July.

Samantha Watkins is busy building time towards her instrument rating.

June 22 we will be interviewing and choosing our next Ray Scholar. We have 4 extremely qualified candidates so it will be a difficult decision to make. The 4 candidates are: Sophia Almond, Sean Londrigan, Ethan Smith and Cody Stebbins.

—[Craig Spoke](#)

Oil Cooler Swap pt. 3

Filling the new oil cooler with oil was difficult since both the In and Out ports are pointed slightly down. This necessitated disconnecting both oil lines from the engine accessory case and in order to do that the Left Pmag ignition needed removal. The Pmag installation is simplified compared to a standard aircraft mag since it's installed in any position and retimed electrically from that position. It's a very easy process compared to traditional mags.

Using a modified funnel with a hose attached I managed to get about 8 oz. into the cooler system. It was a slow process aided by the fact that I'm using Phillips 20w-50w oil which flowed better than a straight 50w in the cooler temperature.

I used both lines for filling until both lines were full. I was sure that the cooler wasn't full but it was a start. I'm sure there is some air in the system and it should work it's way out over several flights.

I took the plane outside un-cowled and ran the engine for a few minutes, shutdown and checked for leaks. When I didn't find any, I started up again and ran it for about 15 minutes till 140 degrees oil temperature and did my normal engine runup at 1800 rpm and then took it up to 2700 takeoff power. Everything checked fine. I checked the engine for leaks and left it open overnight. Inspection in the morning revealed no leaks so I installed the cowling.

A few days later the weather was OK to fly, about 70 degrees temperature. I let the engine warm up to 160 on the ground and went flying. It was a bumpy ride down low. Once clear of the Class C airspace I setup my normal climb of 110-115 KIAS, full power and 2500 rpm. I leveled off at 8500 feet and had 216 oil temp, within Lycoming's normal range. I went over to Mobile and did some high work.

I tested the cabin heat valve by opening the firewall valve. This system was completely "re-plumbed" and it produced warm air. I then did some sightseeing in a slow decent into Jan's making two full stop landings and another full stop at Shields at one point I saw 219 on the oil temp. The old cooler would have been at 240 or more

Satisfied with the new oil cooler, I decided to move on to the last project, cabin heat. I wanted to control the constant loss of cylinder cooling air to the cabin heat system when not in use. The cabin heat system constantly is providing the "heat muff" with warm air from the aft engine baffle and then deposits hot air on the firewall. This robs cooling air from the cylinders and heated hot air inside the cowling at the lower firewall.

All that's necessary is to control the air going to the heat muff with some type of shutoff. Initially I worked on using a knife valve similar to what's used in wood shops to control vacuum at the tools using a manually operated valve that adds or removes that tool from the vacuum system. I even purchased one but that would require a lot of room for the valve and added an additional 2" space for the "knife" movement. I decided I'd roll my own "inline" valve.

The "SCAT" tube slips over a 2" aluminum tube. I had some aluminum tubing in the hangar so I was set. During the Thatcher build we've cut some holes in aluminum sheet and I save these aluminum scraps. I found a 2" one laying around that with slight trimming fit inside the tube perfectly. I used TurboCad to make a quick drawing of what I wanted.

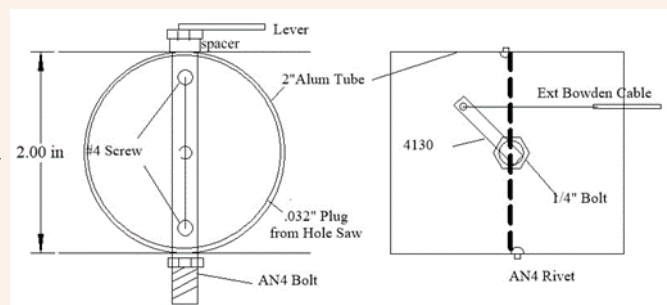

Oil Cooler Swap cont.

I went to my “collection” of AN bolts, washers, nuts etc that were replaced or just not pretty enough for an aircraft. I found an AN4 (1/4”) bolt that was the right length to use. I now had the basic components to make the valve.

A drill press with a tube holder is critical to have a centered hole drilled through the aluminum 2” tubing. The hardest part of building the valve was to “whittle” the inside portion of the bolt flat about 3/16” for the butterfly disc mating.



The only way to do this was with vixen files. It took a good bit of time and trial fitting but finally I had a good surface to work with. I predrilled holes in the aluminum disk to act as a template for marking the AN4 bolt for attachment holes. I used spacers on both ends of the bolt to get the flat part of the bolt centered inside the tube.

Two holes were drilled and tapped to #4 size screws fixing the plate to the AN4 bolt. I also reduced the outside of the disk slightly for a minimal gap on the sides with the tube. This not only eliminates any binding of the valve but allows a small amount of air to circulate through the SCAT tube and heat muff system.



This normally wasted air is now available for engine cylinder cooling by use of a simple Bowden cable from the cockpit. In my opinion a win-win solution.

John



The finished product



Rusty is
Refurbished!



1991 Christavia



total time airframe 718 hrs,
Engine O-235c lycoming, total time 1868 hrs,
15 since overhaul. Val 2000 radio, Narco AT 150
Transponder, \$23,500 contact Seale Williamson
(251) 979 - 5093 Robertsdale, Al same owner last 21
years



DRANO'S ZENITH 750 Update

If you take on a metal airplane building project, you eventually reach the point of having to decide about paint, or vinyl wrap, or polished metal or any combination off the three. The subject of painting an aircraft could fill a 485 Chapter book when considering all the aspects of prepping to paint, when to paint, what to paint, how to paint, where to paint, and how to finish it once it is painted. Buried in each of these aspects is that tricky balance of quality and cost, and there is a Gulf of Mexico between the Krylon and Imron approaches. There is also a huge consideration in the bank account required to do the painting process. I am not an expert nor experienced in any of this and quickly determined that I did not want to do the painting but could do the prep work and the finishing work. This only left the decisions of who was going to do it, when, what color, and where to paint it.

When to paint has choices as well. A common approach is to finish building the plane, fly it through the test phase, then paint it. Some builders fly them for years before painting. Another approach is to paint the major sections of the plane as they are completed then assemble it. The fuselage, tail and wings of my project were largely completed through acid etching to remove aluminum oxide and much of it was also primed so the previous builder had definitely decided to paint. Probably a good choice in our Gulf Coast area. The result though is that the aluminum looks ugly, as in really ugly. OK, the decision is to paint but I don't want to fly it for a year looking like something out of an aircraft salvage yard. We are going to paint early.

I like the color red on small GA aircraft, my RV-6 is red but NEVER paint an aircraft red. Red is one of the hardest colors to match and is one of the most prone to fading.....but I do love red. I have a builder's article in one of my magazines that said to choose a white that matched a commercial rattle can paint so that it was easy to touch up paint around landing gear, fill small nicks, and match paint pieces or fairings that might be replaced or added later. This also allows you to add color later in smaller amounts using paint or vinyl.....think most Cessnas. I also decided that for convenience and cost, I was going to have an automobile painter do the job and I chose a white, automotive, single stage, two part epoxy, paint.

There is a young, newly minted A&P, energetic entrepreneur in our area and I struck a deal with him. I would help set him up with equipment and all the costs and let him shoot the paint. I won't go into the details of our agreement but he wanted the experience and I wanted the project painted. At this point in the article, I know I have opened a "can of worms" in the aircraft painting debate but it was a mutually beneficial agreement on many levels.....especially cost. There are some big compromises too. —Drano

The first picture is of my project primed, prepped, and loaded up to go get painted. The right is after it came back from the painter. Next month I'll discuss dealing with the dreaded "Orange Peel" effect in paint. Ugh!



Before the first coats of white paint.



After being painted.

She flew a record-breaking US flight, but it was kept secret for years

Pt. 1

Lynn Rippelmeyer's reach for the sky started from an unlikely place. "I grew up on a farm in the 1950s. There were no women flying, there were no female airline pilots. I had an interest in aviation because there were airplanes flying overhead, and I thought how much fun it would be to see the world from up there. The closest I could come to pretending that was riding my horse up to the top of these limestone bluffs overlooking the Mississippi River, about a mile away from the farm, and imagine that the horse had wings — like Pegasus — and could soar and fly over the fields."



Lynn Rippelmeyer sits in the captain's seat of a Boeing 747 in 1984, seven years after she piloted a flight that made aviation history.

So, she did the next best thing: become a flight attendant. She got [hired](#) in 1972 by TWA, then a major airline, and started working on the Queen of the Skies, the Boeing 747: "It had just come out, and TWA was one of the first airlines to fly it. I loved how it looked," she says.

However, she was mostly curious about how it worked: "If I started asking questions about what was going on in the cockpit and asked [the flight crew] about their jobs and the airplane, we could have an almost intelligent adult conversation, and I could sit up there and enjoy it, so that's what I did."

At the time, flight crews on large aircraft were made up of two pilots plus a flight engineer, who was easier to talk to because his seat was positioned behind those of the pilots.



Rippelmeyer and Captain Emilie Jones before a flight with Air Illinois, where they became the first all-female crew of a scheduled flight in the United States.
Courtesy Lynn Rippelmeyer

Lynn Rippelmeyer cont.

Rippelmeyer's first cockpit job came just a year later with a small commuter airline, Air Illinois, as first officer on a Twin Otter — a 20-passenger turboprop regional plane. The airline already had a female captain in its ranks, but upon hiring Rippelmeyer, the owner told her that they would be never flying together. "I asked why, and he said, 'Well, we have to have a man up there in case anything goes wrong, don't we? And we also don't want to scare our passengers away, do we?' Because he was the owner, he could make whatever rules he wanted. And at that time, there was no law or regulation against it, so we just went with it." However, with only three airplanes and about 20 pilots, keeping the two women from flying together was a scheduling nightmare. "One day, we just had to — Emilie, the captain, was already there, but her first officer was sick and there was nobody else that could get to the airplane on time but me," Rippelmeyer said.

She had the dispatcher call the owner of the airline and heard him screaming through the phone: "He said I could take the flight, but we couldn't make any announcements and we had to keep the cockpit door closed. Nobody had to know there were two women in there. So that's what we did."

It was December 30, 1977, and that was the first scheduled flight in the United States with an all-female crew — but it was kept a secret. At least, "since nobody died," Rippelmeyer says, the two were no longer intentionally kept apart and flew together many more times. However, her days at Air Illinois were numbered: "The pay for being a first-year pilot wasn't even enough to make rent," she says. To make ends meet, she was still working as a flight attendant, resulting in a grueling schedule: "I couldn't do both. I tried for about a month and there should be a rule against it. But at Air Illinois, I had a goal: I needed 1,000 hours of gas-turbine flight time. And once I had that, there really wasn't any more reason to hang out there."

Too short to be a pilot?

With enough flight experience in her pocket, Rippelmeyer could take a crack at bigger airlines. One of them — the now defunct Ozark Air Lines — rejected her at the end of the interview process because, they said, at 5'4" she was too short to be a pilot: "I knew I wasn't, but again, they could make whatever rules they wanted."

She got hired by TWA as a flight engineer, flying on the Boeing 727. The airline had two other female pilots, and they got along well. However, they all got furloughed just a week short of being off probation: "You can't wait to get off probation, because your salary doubles — the first year at any airline is poverty," she says.



Trans World Airlines (TWA) was founded in 1930 and ceased operations in 2001, when it was absorbed into American Airlines.

What a Difference a Decade Makes: the GA boom in statistics

April 15, 2024

Part 2/2

By John Zimmerman

Turboprops have grown more slowly than jets, but beneath that headline it's clear that single engine turboprops have arrived. Airplanes like TBMs, PC-12s, and Meridians are slowly replacing King Airs and Conquests; they flew 1.63 million hours 2022, compared to 1.37 million in 2012. In 2022, 55% of GA turboprops were single engine, up from 49% in 2012. Among owner-flown airplanes this is almost certainly higher, since many twin turboprops these days are part of fractional or charter fleets.

In addition to turboprop twins, single engine turboprops are also slowly pushing piston twins into a training niche. This category, led by trusty designs like the Seminole and Cessna 310, flew just 1.43 million hours in 2022, down from 1.77 million hours in 2012.

Is the glass half empty?

Of course there are important details to consider, and those pilots who survived previous downturns may be itching to jump in with a reminder about how quickly trends can reverse. Look closely and the industry does indeed seem to be at an inflection point. For a start, the airline pilot hiring boom has probably peaked, as many regional airlines and [investment banks have pointed out](#) recently. Hiring at major US airlines was down almost 25% in January and February 2024 compared to the previous year. Some airlines have even paused hiring completely, including big names like Southwest and FedEx.

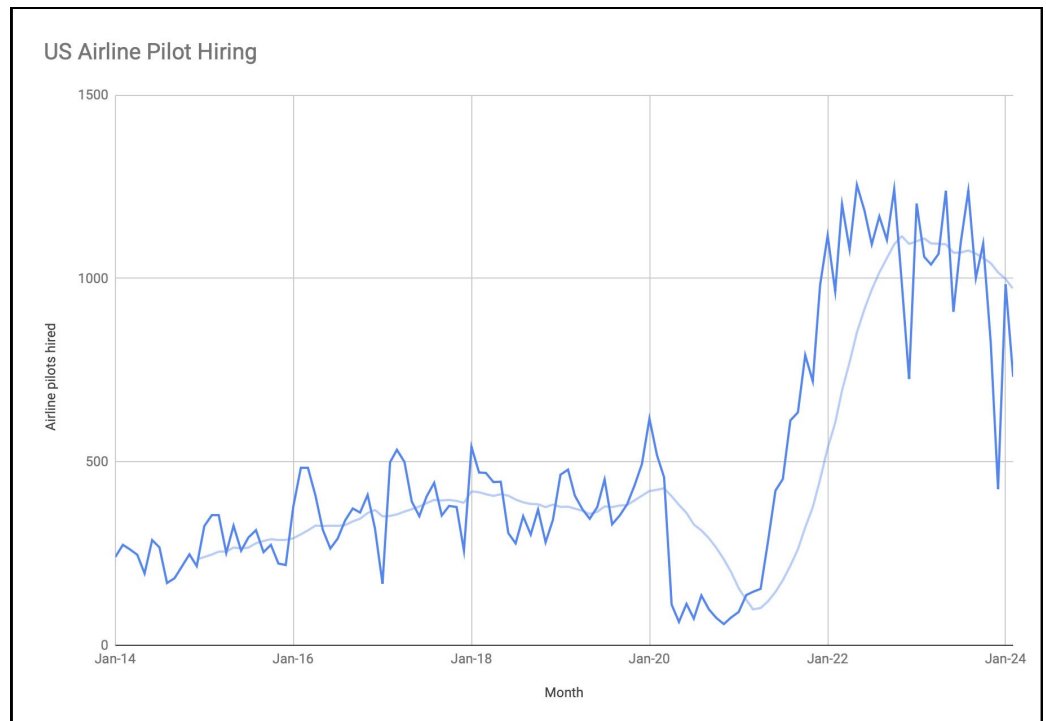

But while the headlines are occasionally negative, pilot hiring is hardly weak. Compared to 2018-2019, pilot hiring is still up nearly 100% in early 2024. The reality is that the acute phase of the shortage (driven mostly by Covid) is over, but the chronic phase (driven mostly by long-term demographics) is still very much a factor. In fact, some of the recent struggles have more to do with delayed airplane deliveries, in particular the Boeing 737 MAX, than changes in demand. One look at the long term hiring trend shows that the trend may have plateaued, but at a very high rate.

GA Boom in Statistics cont.

The more serious concern is that the training boom is hiding weakness in owner-flown GA airplanes, the classic Cessna 182 and Beechcraft Bonanza operators who use light airplanes for a mix of family and business transportation. Once again, the headlines are not great: Beechcraft essentially stopped taking orders for Bonanzas and Barons last year, Cessna shipped just 66 Skylanes last year, and Icon recently filed for bankruptcy.

It's more than just headlines that support the glass half empty theory; FAA data shows some worrying trends. Original certificate issuances (meaning a new certificate or rating, not a reissue) are way up for Student pilots, from 49,000 in 2014 to over 69,000 in 2023, but active Private pilots are down from 174,883 to 167,711. Measuring "active pilots" is hard, but the trend suggests all those student pilots are not leaving a lasting impact on GA—we're losing as many Private pilots as we're gaining. If nothing else, most students are moving right on to a Commercial or ATP certificate, passing through GA as they move into pro pilot jobs. That's good for the industry while they're training, but doesn't make much of a long term impact.

And of course if you want to argue that the glass is completely empty, just look at FAA statistics from the late 1970s and early 1980s: today's 167,000 active Private pilots pale in comparison to the 357,000 in 1980!

But that's an unfair comparison, a bubble that is never coming back. For now we can confidently say that GA is growing and has been for nearly a decade. New people from all walks of life are coming into the aviation industry, and flying is considered cool again, whether it's bush pilots on YouTube or Tom Cruise on the big screen. Bonanzas and Skylanes may not be flying off the shelves, but Cirrus SR20s and SR22s are: over 600 were delivered in 2023. Sure they're expensive, but the company has been successful by responding to customer desires and constantly improving their product. They've found a market, even at \$1 million per airplane. The cycle may soon turn, but the pessimists would do well to remember what poet Randall Jarrell once wrote: "The people who live in a golden age usually go around complaining how yellow everything looks."

May 11, 2024 Meeting

VMC/IMC Club Meeting

VMC: Mushy controls on tight turn-to-final

IMC: Low fuel in IFR conditions

General Membership Meeting

Ray Scholarship – Craig Spoke

The scholarship process is moving right along. We should have inter views scheduled for the end of June.

Guest Speaker – Virgil Zetterlind

Go-Pro Camera mounting on air craft

—[Jacob Abston](#), Secretary

Just like Drano, I have my own painting problems. I tried to fix up an old helmet, because I was headed to an airshow and the one I had been using was too big. I called so many paint shops, but since nobody wanted to take the project on, I was forced to try it myself. Surprisingly, I didn't have any drips or orange peel and I gave it plenty of time to dry between coats. Then things took a turn. As I sprayed on the very last coat—a clear gloss finish—suddenly, all the paint turned into little fractionated cracks. I have no idea what happened or what caused it. It did slightly disappear after I let it sit and dry, but I'll definitely skip it next time... —Courtney





2024 Officers and Committee Chairmen

President:	Ralph Moser (847) 736-4603
Vice President:	Mark Rogers (251) 228-0356
Tech Counselor	
Flight Advisor:	
Secretary:	Jacob Abston (251)424-5004
Treasurer/Membership:	Scott Swanson (309)267-9710 711 Marlinspike Dr. Pensacola, FL 32507
Ray Scholarship Coordinator:	Craig Spoke (251) 550-5795
Young Eagles Coordinator:	Eric Goldman (317) 910-2513
Webmaster:	Doug Francisco (850) 453-5501

EAA and Local Chapter Sites

- [EAA 485](#)
- [EAA HDQTRS](#)
- [Interesting Links](#)
- [Blue Angel 360 Way cool](#)
- [Making the First Airbus 220 Time Lapse](#)
- [Jetman Unleashed in Dubai](#)
- [Boeing 737 Time Lapse Build](#)
- [F-18 Low Level](#)
- [High Speed Carrier Maneuvering](#)
- [Miscellaneous](#)
- [1800wxbrief.com](#)
- [FAA Notams](#)
- [Barnstormers](#)
- [Skyvector.com](#) Flight Planning, Charts
- [AirNav.com](#) Airport info, Fuel Prices

Normally meetings will be held at [Roscoe Field Airport \(82J\) \(Uni 122.8\)](#) on the **Second Saturday of each month at 10:00 AM unless otherwise posted. If flying in, check NAS Pensacola (KNPA) NOTAMS for possible TFRs and the Roscoe Field Airport website under the Arrivals tab for important arrival and departure information.**

Driving: From Hwy 98 go past the main airport entrance and take the next left. Go thru the gate and make a left on the gravel road. Make a right past the T hangars you'll see our building down on the left side. Anyone interested in sharing general aviation, aircraft building, maintaining and restoring is welcome.

For more info contact:

[Ralph Moser](#) (847) 736-4603





June 2024

EAA 485
news



Home Of The
PANHANDLE PELICANS

EAA 485 Pensacola, FL

Get Your Chapter Ballcap

We have ballcaps with chapter logo for sale for \$20. Get yours before the price hike. The next batch will be more expensive so don't wait!



Upcoming Events

(CHAPTER EVENTS IN CAPS):

June 8th, "[Rockin' On The Runway](#)", Red Oak Landing (51LS)

JUNE 15TH, CHAPPIE JAMES FLIGHT ACADEMY YOUNG EAGLES FLYING

July 6th, JULY MEETINGS (1st weekend due to Beach Air Show on 13th)

July 13th, [Pensacola Beach Air Show](#)

July 22-28, [Air Venture 2024](#), Oshkosh, WI (KOSH)

October ??, FALL YOUNG EAGLES RALLY

November 1-2, [Blue Angels Homecoming Show](#)

Chapter Meetings:

Saturday, June 8th, 2024

08:30-09:30, VMC/IMC Club Meeting.

10:00-11:00, General Membership Meeting.

Pledge

Guests

Officers Reports: President, Vice-President, Secretary, Treasurer/
Membership

Young Eagles – Eric Goldman

Ray Scholarship – Craig Spoke.

Member Build Projects Update

Guest Speaker: Details on recent aircraft kit donation to chapter + bid process

Adjourn

Cheeseburger Lunch

CHAPTER DUES: Chapter dues are due for members who have not already paid their dues for 2024. Dues are \$25 per year and can be paid during the meetings or mailed to [Scott Swanson](#).

Scott Swanson

711 Marlinspike Dr.

Pensacola, FL 32507

OSHKOSH ALERT!

[UW-Oshkosh Dorm Room Reservations](#)

Open Now for [Air Venture 2024](#)
Jul 22-28